

10 9 8 7 6 5 4 3 2 1

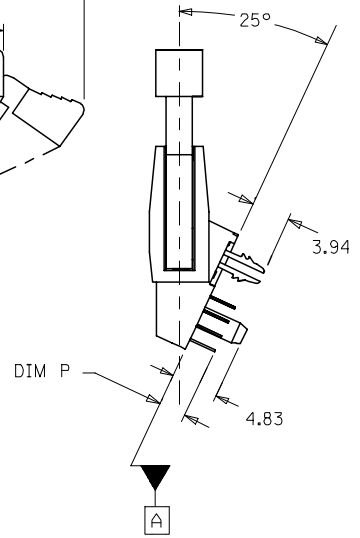
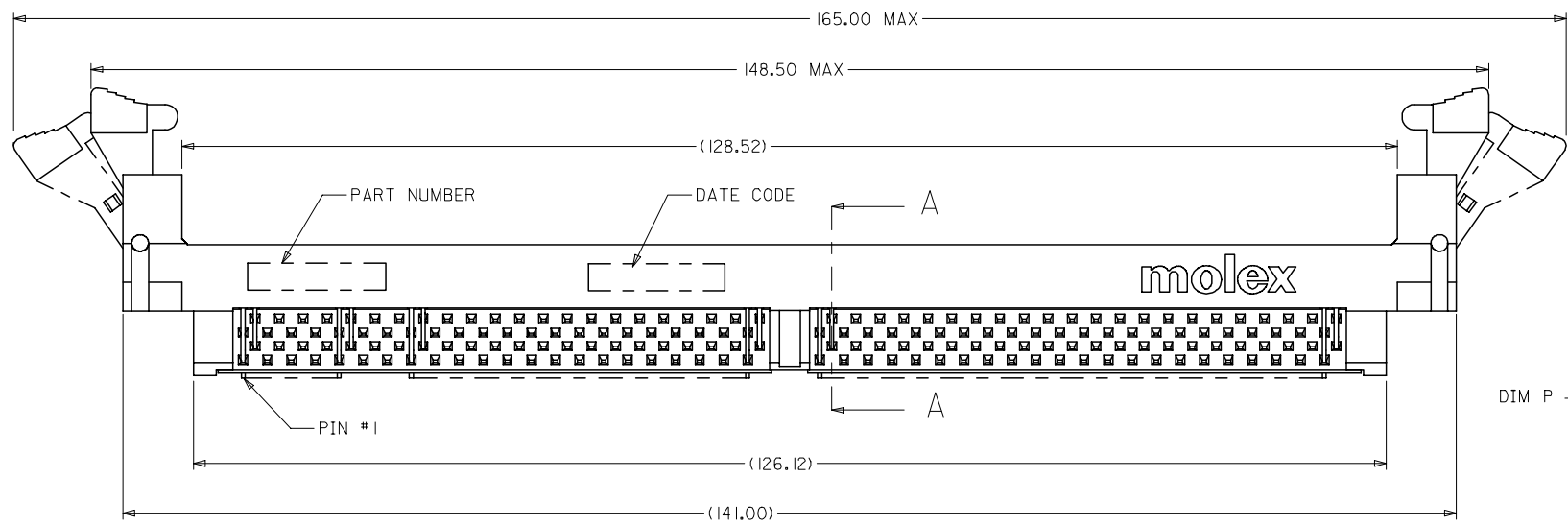
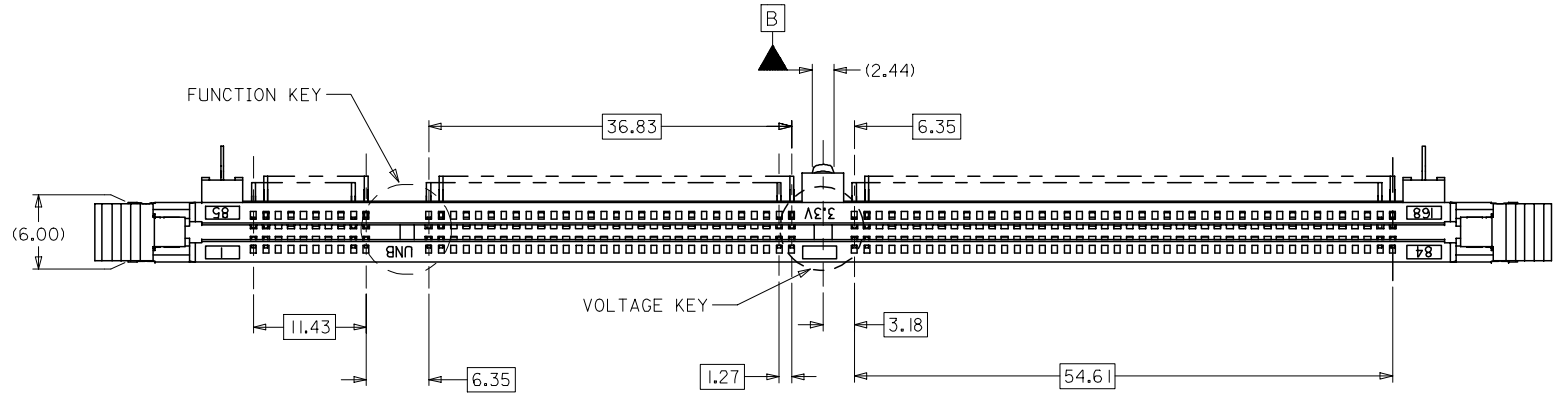

- NOTES:
- MATERIALS: HOUSING AND LATCH - HIGH TEMPERATURE THERMOPLASTIC, UL 94-V0
TERMINAL AND FORKLOCK - COPPER ALLOY
 - FINISHES: CONTACT AREA: SEE TABLE ON SHEET 3
SOLDER TAILS: 2.54uM/100u" MIN. TIN/LEAD OR TIN
 - PRODUCT SPECIFICATIONS: PS-87587-007 FOR PERFORMANCE SPECIFICATIONS.
 - DATE CODE SHALL BE MARKED LEGIBLY AS SHOWN: XX XXX YEAR DAY
 - PART NUMBER SHALL BE MARKED LEGIBLY AS SHOWN: 87587-0XXX REFER TO THE TABLE

ADD ASSY P/N FOR LF	2004/08/19
EC NO: S2004-0549	2004/08/19
DRWN: JAN	2004/08/19
CHKD: ATSEE	2004/08/20
APPR: SKTOH	
REV	DESCRIPTION

QUALITY SYMBOLS	$\nabla = 0$
	$\nabla \square = 0$

GENERAL TOLERANCES (UNLESS SPECIFIED)	mm	INCH
4 PLACES	\pm ---	\pm ---
3 PLACES	\pm ---	\pm ---
2 PLACES	\pm 0.25	\pm ---
1 PLACE	\pm ---	\pm ---
ANGULAR \pm 5 °		
DRAFT WHERE APPLICABLE MUST REMAIN WITHIN DIMENSIONS		

DIMENSION STYLE		SCALE	DESIGN UNITS	THIRD ANGLE PROJECTION
MM ONLY		NTS	METRIC	\square
DRAWN BY	DATE	TITLE		
LPL IM	1999/03/19	SALES DRAWING		
CHECKED BY	DATE	1.27MM PITCH, 168 CKTS		
KCL ING	1999/06/14	MULTI-KEY DIMM, 25 DEG		
APPROVED BY	DATE	MOLEX INCORPORATED		
SKTOH	1999/06/15	MOLEX INCORPORATED		
MATERIAL NO.	DOCUMENT NO.	SHEET NO.		
SEE TABLE	SD-87587-001	1 OF 4		
SIZE A3	THIS DRAWING CONTAINS INFORMATION THAT IS PROPRIETARY TO MOLEX INCORPORATED AND SHOULD NOT BE USED WITHOUT WRITTEN PERMISSION			

9 8 7 6 5 4 3 2 1

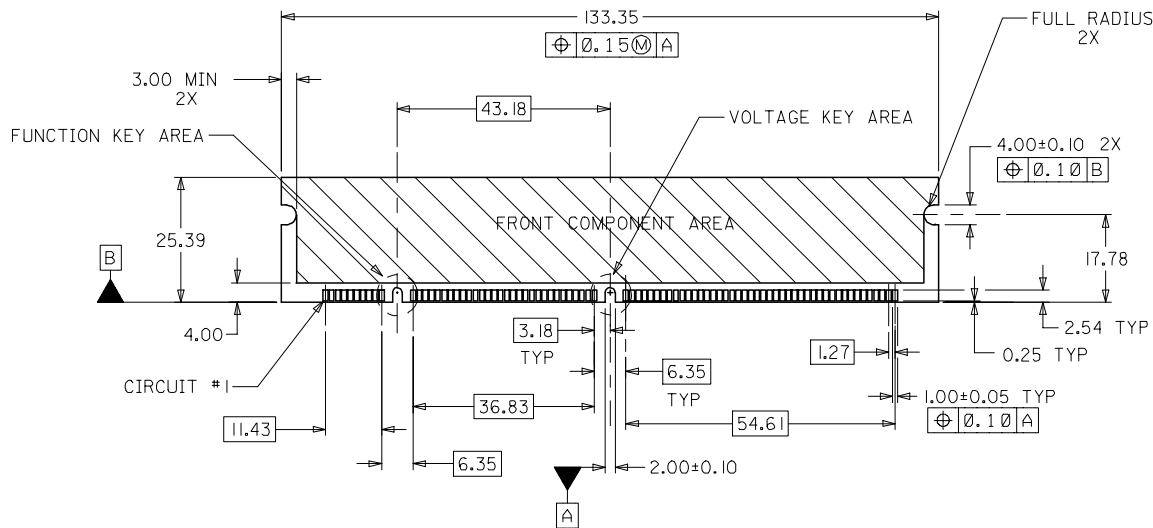

RECOMMENDED MODULE LAYOUT
(PER JEDEC STANDARD MO-161, 168 CKT, 3.3V)

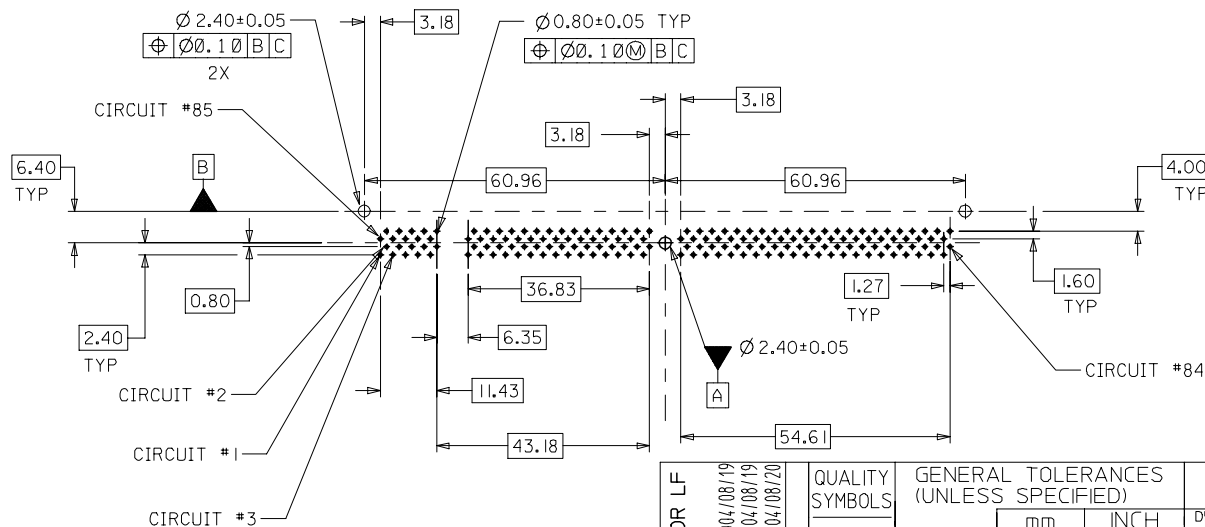

RECOMMENDED
P.C. BOARD HOLE PATTERN
(CONNECTOR SIDE)

FUNCTION KEY AREA OPTIONS
(REFER ALSO TO TABLE ON SHT. 3)

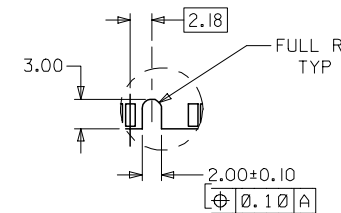

OFFSET LEFT KEY

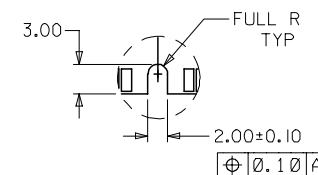

CENTERED KEY

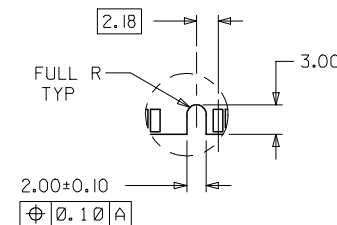

OFFSET RIGHT KEY

ADD ASSY P/N FOR LF EC NO: S2004-0549 DRAWN: JAN 2004/08/19 CHKD: ATSEE 2004/08/19 APPR: SKTOH 2004/08/20	QUALITY SYMBOLS ▽=0 ▽=0	GENERAL TOLERANCES (UNLESS SPECIFIED)		DIMENSION STYLE MM ONLY	SCALE NTS	DESIGN UNITS METRIC	THIRD ANGLE PROJECTION																
		<table border="1"> <thead> <tr> <th></th> <th>mm</th> <th>INCH</th> </tr> </thead> <tbody> <tr> <td>4 PLACES</td> <td>± ---</td> <td>± ---</td> </tr> <tr> <td>3 PLACES</td> <td>± ---</td> <td>± ---</td> </tr> <tr> <td>2 PLACES</td> <td>± 0.25</td> <td>± ---</td> </tr> <tr> <td>1 PLACE</td> <td>± ---</td> <td>± ---</td> </tr> </tbody> </table>			mm	INCH	4 PLACES	± ---	± ---	3 PLACES	± ---	± ---	2 PLACES	± 0.25	± ---	1 PLACE	± ---	± ---	DRAWN BY DATE LPL IM 1999/03/19		TITLE SALES DRAWING 1.27MM PITCH, 168 CKTS MULTI-KEY DIMM, 25 DEG		
			mm	INCH																			
		4 PLACES	± ---	± ---																			
3 PLACES	± ---	± ---																					
2 PLACES	± 0.25	± ---																					
1 PLACE	± ---	± ---																					
ANGULAR ± 5 °		CHECKED BY DATE KCL ING 1999/06/14		MOLEX INCORPORATED																			
DRAFT WHERE APPLICABLE MUST REMAIN WITHIN DIMENSIONS		APPROVED BY DATE SKTOH 1999/06/15		MATERIAL NO. DOCUMENT NO. SEE TABLE SD-87587-001		SHEET NO. 2 OF 4																	

10 9 8 7 6 5 4 3 2 1

F
E
D
C
B
A

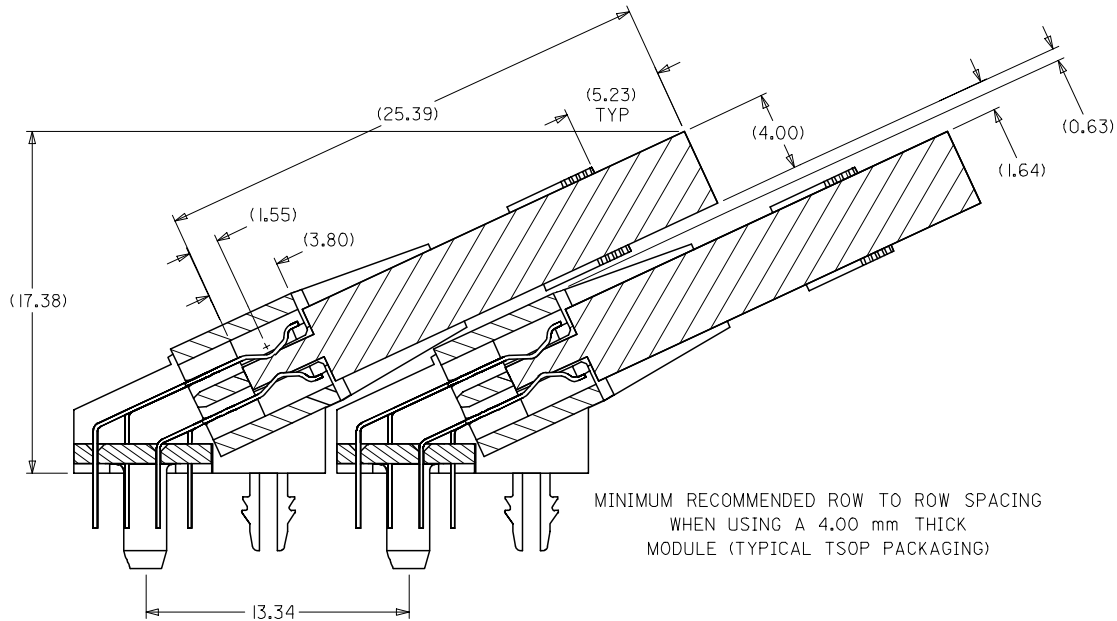

MINIMUM RECOMMENDED ROW TO ROW SPACING
WHEN USING A 4.00 mm THICK
MODULE (TYPICAL TSOP PACKAGING)

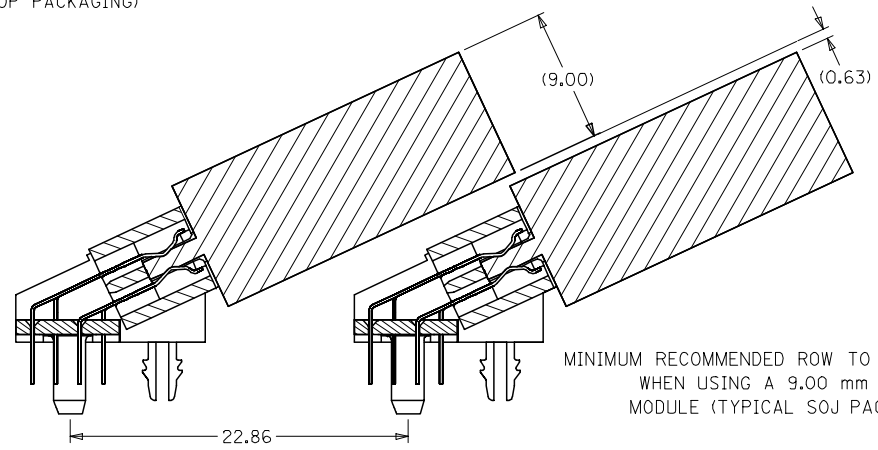

MINIMUM RECOMMENDED ROW TO ROW SPACING
WHEN USING A 9.00 mm THICK
MODULE (TYPICAL SOJ PACKAGING)

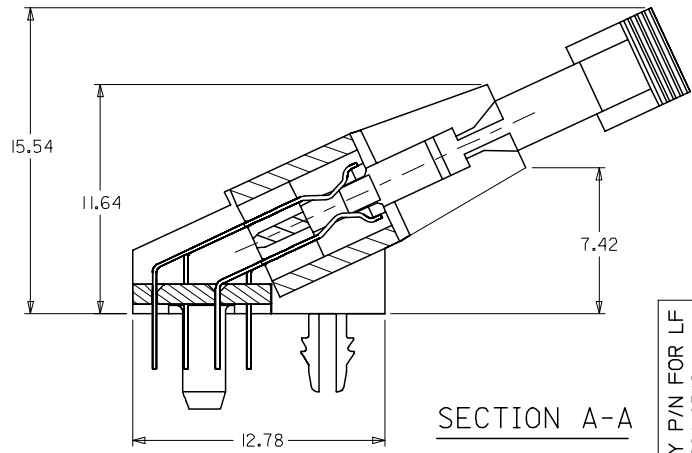

SECTION A-A

ADD ASSY P/N FOR LF	2004/08/19
EC NO: S2004-0549	2004/08/19
DRWN: JIAN	2004/08/19
CHKD: ATSEE	2004/08/20
APPR: SKTOH	
REV	DESCRIPTION

QUALITY SYMBOLS	$\nabla=0$
	$\sphericalangle=0$

GENERAL TOLERANCES (UNLESS SPECIFIED)	
	mm INCH
4 PLACES	\pm --- \pm ---
3 PLACES	\pm --- \pm ---
2 PLACES	\pm 0.25 \pm ---
1 PLACE	\pm --- \pm ---
ANGULAR \pm 5 °	
DRAFT WHERE APPLICABLE MUST REMAIN WITHIN DIMENSIONS	

DIMENSION STYLE	
MM ONLY	
DRAWN BY	DATE
LPL IM	1999/03/19
CHECKED BY	DATE
KCL ING	1999/06/14
APPROVED BY	DATE
SKTOH	1999/06/15
MATERIAL NO.	DOCUMENT NO.
SEE TABLE	SD-87587-001
SIZE	
A3	

SCALE	DESIGN UNITS	THIRD ANGLE PROJECTION
NTS	METRIC	\odot \square
TITLE		
SALES DRAWING		
1.27MM PITCH, 168 CKTS		
MULTI-KEY DIMM, 25 DEG		
MOLEX INCORPORATED		
DOCUMENT NO.	SHEET NO.	
SD-87587-001	3 OF 4	
THIS DRAWING CONTAINS INFORMATION THAT IS PROPRIETARY TO MOLEX INCORPORATED AND SHOULD NOT BE USED WITHOUT WRITTEN PERMISSION		

9 8 7 6 5 4 3 2 1

	10	9	8	7	6	5	4	3	2	1					
F		PLATING OPTION	MATERIAL NO.	FUNCTION KEY	DATUM VOLTAGE KEY	TAIL LENGTH P±0.25	FINISHES: CONTACT AREA	PLATING OPTION	MATERIAL NO.	FUNCTION KEY	DATUM VOLTAGE KEY	TAIL LENGTH P±0.25	FINISHES: CONTACT AREA	F	
		TIN	87587-2048	LEFT	CENTER (3.3V)	2.79	SELECTIVE GOLD 0.38µm/15u" MIN. GOLD OVER 1.27µm/50u" MIN. NICKEL	TIN/LEAD	87587-0048	LEFT	CENTER (3.3V)	2.79	SELECTIVE GOLD 0.38µm/15u" MIN. GOLD OVER 1.27µm/50u" MIN. NICKEL		
	87587-2049		CENTER			↓			87587-0049	CENTER				↓	
	87587-2050		RIGHT			↓			87587-0050	RIGHT				↓	
	87587-2057		LEFT			3.18			87587-0057	LEFT				3.18	
	87587-2058		CENTER						87587-0058	CENTER					
	87587-2059		RIGHT				87587-0059		RIGHT						
	87587-2148		LEFT			2.79	SELECTIVE GOLD 0.76µm/30u" MIN. GOLD OVER 1.27µm/50u" MIN. NICKEL		87587-0148	LEFT			2.79	SELECTIVE GOLD 0.76µm/30u" MIN. GOLD OVER 1.27µm/50u" MIN. NICKEL	
	87587-2149		CENTER						87587-0149	CENTER					
	87587-2150		RIGHT						87587-0150	RIGHT					
	87587-2157		LEFT			3.18			87587-0157	LEFT			3.18		
	87587-2158	CENTER				87587-0158		CENTER							
E		87587-2159	RIGHT												

ADD ASSY P/N FOR LF EC NO: S2004-0549 DRAWN: JIAN CHKD: ATSEE APPR: SKTOH	2004/08/19 2004/08/19 2004/08/20	DESCRIPTION REV	QUALITY SYMBOLS	GENERAL TOLERANCES (UNLESS SPECIFIED)	DIMENSION STYLE	SCALE	DESIGN UNITS	THIRD ANGLE PROJECTION															
			= 0 = 0	<table border="1"> <tr> <td></td> <td>mm</td> <td>INCH</td> </tr> <tr> <td>4 PLACES</td> <td>± ---</td> <td>± ---</td> </tr> <tr> <td>3 PLACES</td> <td>± ---</td> <td>± ---</td> </tr> <tr> <td>2 PLACES</td> <td>± 0.25</td> <td>± ---</td> </tr> <tr> <td>1 PLACE</td> <td>± ---</td> <td>± ---</td> </tr> </table>		mm	INCH	4 PLACES	± ---	± ---	3 PLACES	± ---	± ---	2 PLACES	± 0.25	± ---	1 PLACE	± ---	± ---	MM ONLY	NTS	METRIC	
				mm	INCH																		
			4 PLACES	± ---	± ---																		
			3 PLACES	± ---	± ---																		
2 PLACES	± 0.25	± ---																					
1 PLACE	± ---	± ---																					
			<table border="1"> <tr> <td>DRAWN BY</td> <td>DATE</td> <td>TITLE</td> </tr> <tr> <td>LPL IM</td> <td>1999/03/19</td> <td rowspan="3"> SALES DRAWING 1.27MM PITCH, 168 CKTS MULTI-KEY DIMM, 25 DEG </td> </tr> <tr> <td>CHECKED BY</td> <td>DATE</td> </tr> <tr> <td>KCL ING</td> <td>1999/06/14</td> </tr> </table>	DRAWN BY	DATE	TITLE	LPL IM	1999/03/19	SALES DRAWING 1.27MM PITCH, 168 CKTS MULTI-KEY DIMM, 25 DEG	CHECKED BY	DATE	KCL ING	1999/06/14										
DRAWN BY	DATE	TITLE																					
LPL IM	1999/03/19	SALES DRAWING 1.27MM PITCH, 168 CKTS MULTI-KEY DIMM, 25 DEG																					
CHECKED BY	DATE																						
KCL ING	1999/06/14																						
			<table border="1"> <tr> <td>APPROVED BY</td> <td>DATE</td> <td rowspan="2"> MOLEX INCORPORATED </td> </tr> <tr> <td>SKTOH</td> <td>1999/06/15</td> </tr> </table>	APPROVED BY	DATE	MOLEX INCORPORATED	SKTOH	1999/06/15															
APPROVED BY	DATE	MOLEX INCORPORATED																					
SKTOH	1999/06/15																						
			<table border="1"> <tr> <td>MATERIAL NO.</td> <td>DOCUMENT NO.</td> <td>SHEET NO.</td> </tr> <tr> <td>SEE TABLE</td> <td>SD-87587-001</td> <td>4 OF 4</td> </tr> </table>	MATERIAL NO.	DOCUMENT NO.	SHEET NO.	SEE TABLE	SD-87587-001	4 OF 4														
MATERIAL NO.	DOCUMENT NO.	SHEET NO.																					
SEE TABLE	SD-87587-001	4 OF 4																					